

SCALEMIN

Scaler



Hydraulic diesel Scaler for tunnels in underground mining application, maximum range 7.70 m height, minimum 4.00 m.

Electricity is not required to operate.

Equipped with Montabert SC 28 hammer, special for Scaler application, easy maintenance and durable parts.

4WD vehicle, heavy-duty chassis with central articulation and oscillating rear axle. Also equipped with FOPS / ROPS Certified enclosed cabin with A/C.

ESPECIFICATIONS

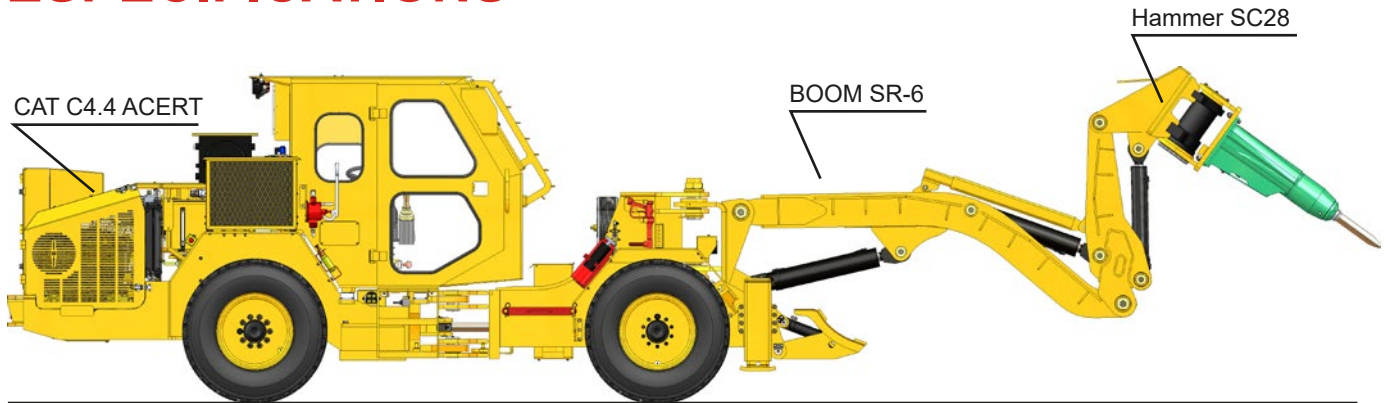

BOOM SR-6

- Boom slew +/- 50°
- Max. vertical reach of hammer 7.70 m
- Max. horizontal reach of hammer 6.90 m
- Hammer turn +/- 60°
- Hammer tilt 120°

MONTABERT SC28 HAMMER

- Power 15 kW
- Frequency 1420 bpm
- Weight 275 kg
- Flow 40 - 75 L/min

DIESEL ENGINE

- CAT C4.4 ACERT, Tier 4 106 kW

TRAMMING

- Horizontal Up to 15 kph
- Ramps 14° Up to 7 kph

BRAKES

- Hydrostatic parking brakes SAHR (Spring Applied Hydraulic Release)
- Service brakes Hydrostatic

CANOPY

- FOPS/ROPS

TRANSMISSION

- Hydrostatic system with (4) Poclain MS18 motors
- Oscillating rear axle 15°

TYRES

- (4) tyres 12 x R20

STEERING

- Hydraulic directional system
- Orbitrol type
- Frame articulation +/- 40°

VEHICLE

- 4WD Heavy duty carrier, articulated
- Tropical cooler powered by hydraulic motor
- (2) hydraulic jacks
- Rexroth A10VO71 and triple series
- CR5 Grundfos Water pump with hydraulic motor
- Compressor LER7-10 for hammer lubrication
- Automatic lubrication system L30-C8-00
- Automatic fire suppression system ANSUL
- Push Plate



DIMENSIONS

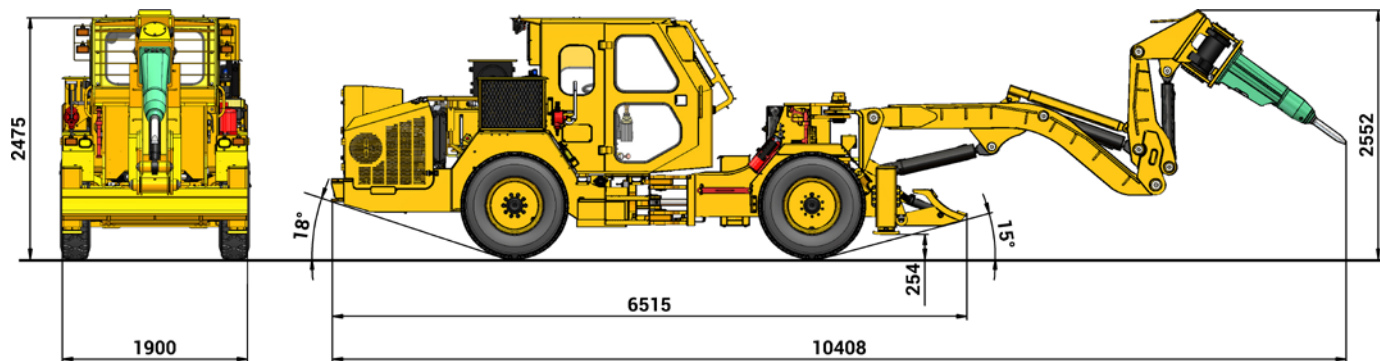

TURNING RADIUS

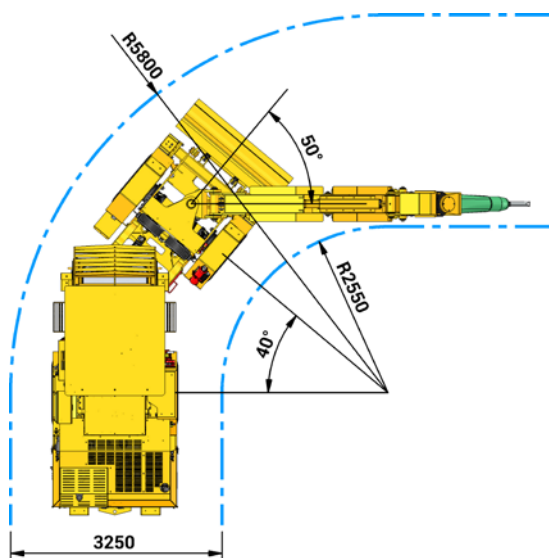

Total weight	14,500 Kg.
--------------	------------



COVERAGE AREA

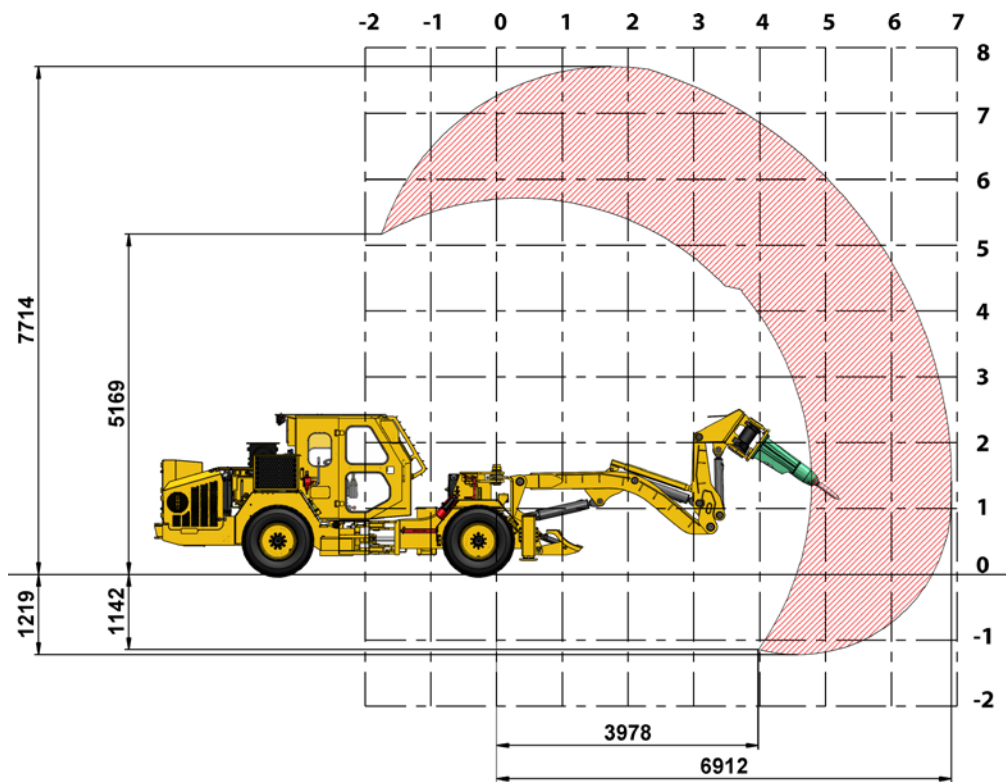
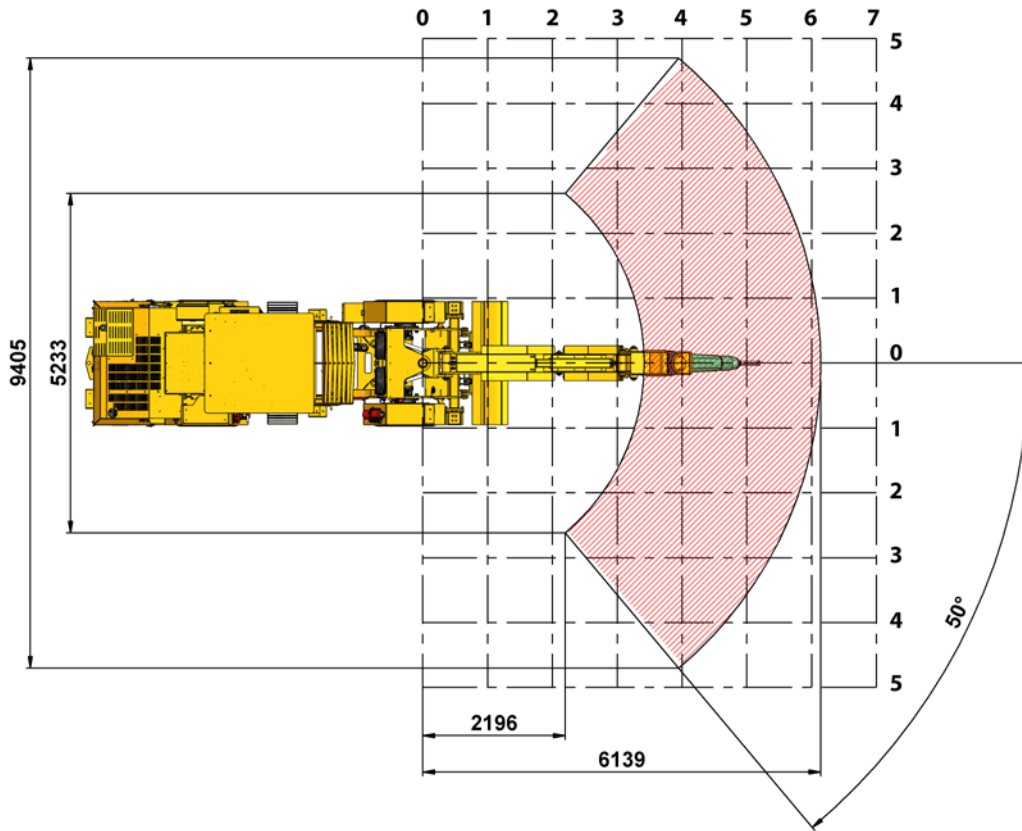

Rev. 050918 © Copyright 2016 RESEMIN. Specifications and equipment are subject to change without further notice.