

HAULMASTER 800-30 is a powerful, fast, and reliable haul truck designed for safe and rapid hauling in demanding underground applications.

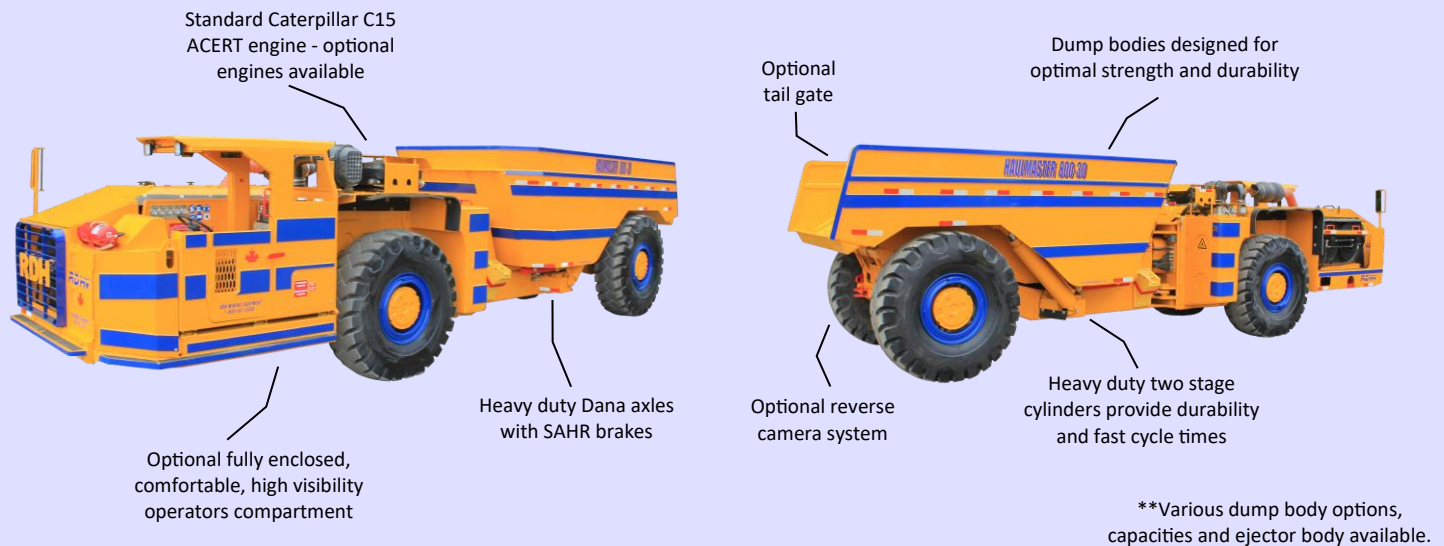

The robust and reliable four-wheel drive, articulated Haulmaster 800-30 consists of a power-shift transmission powered by a choice of diesel engines connected to heavy-duty Dana axles. The rugged frame and articulated carrier make the Haulmaster 800-30 a very durable and extremely maneuverable unit even in the tightest situations. The underground mining haul truck has been designed to provide high production cost-efficient hauling in underground mining and tunneling operations. With its ease of maintenance and robust construction, the Haulmaster 800-30 will ensure production goals are met in a safe, timely, and cost-efficient manner.

FEATURES:

- Standard dump body volume of 13.63 m³
- Up to 30000 kg payload capacity
- Spring applied hydraulic release (SAHR) brakes
- Various dump body capacities/styles available to suit customer requirements
- Powerful, clean burning, U.S. EPA Tier 3, EU Stage III A diesel engine
- Optional ride control available for smoother, more comfortable travel experience
- Fully enclosed, climate controlled personnel compartment option available



SPECIFICATIONS:

DUMP BODY CAPACITIES

Payload capacity	30000 kg (66139 lbs)
Standard box volume (SAE heaped)	13.63 m ³ (17.8 yds ³)

MISCELLANEOUS

Central grease point – manual
Standard gauges and instrumentation
ANSUL fire suppression system - manual
Copy of Parts/Operator/Service manuals
Suspension seating
ROPS/FOPS certified canopy – operator compartment

ENGINE

Cat® C15 ACERT, inline 6, 4 stroke cycle, diesel	
U.S. EPA Tier 3, EU Stage III A	
Power rating @ 1800-2200 rpm	354-433 kW (475-580 hp)
Compression Ratio	17.0:1
Displacement	15.2 L (927.6 in ³)
Exhaust: catalytic purifier with silencer	
Fuel tank volume	398 L

TRANSMISSION

Transmission, Dana 6000 series
4 speeds forward and reverse, 4 wheel drive
Converter, Dana 9000 series

AXLES

Dana 19D, planetary type	
Oscillation (front axle)	± 7°

BRAKES

Service: wet disc (integrated), internal SAHR
Emergency & parking: SAHR

TIRES

Mine type, 18.00 x 25

STEERING

Hydraulic, articulated	
Steering angle	± 42°

HYDRAULICS

Steering and hoist	
170 bar, 190 L/min/2200 rpm	
Hydraulic oil tank volume	379 L

ELECTRICAL SYSTEM

24 V	
Battery	2 x 12 VDC
Tramming/working LED lights	4 front / 4 rear
Brake lights	2 rear
Horn & reverse alarm	



RDH Mining Equipment Ltd.
904 Hwy. 64, Alban, ON, Canada P0M 1A0
Tel: 705-857-2154
info@rdhminingequipment.com
www.rdhminingequipment.com

HM800-30
HAUL TRUCK
Page 3 of 4

OPTIONAL EQUIPMENT

Various engine makes/models	ROPS/FOPS approved enclosed cabin
Various dump body capacities	Ejector dump body
Automatic centralized lubrication system	Dump body liner
24 V hydraulic oil transfer pump	Wheel chocks
Fast fill system	Driver door interlock
Cold weather package	ANSUL Checkfire fire suppression system
Strobe light	Reverse camera system
Swivel seat	Air ride seating
Exhaust system wrap	Remote brake release for towing
Solid or foam filled tires	Other options available upon request

MEASUREMENTS

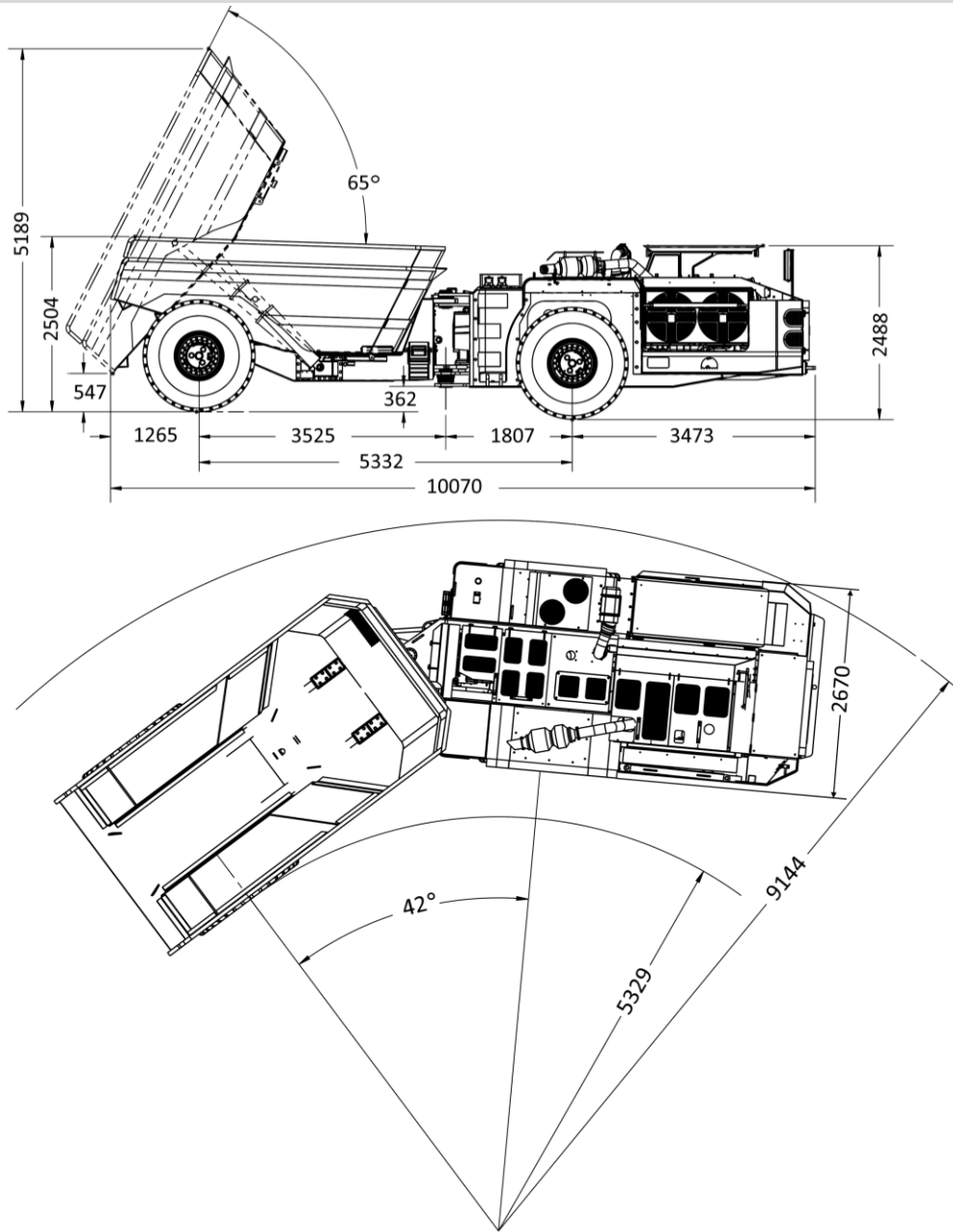

DIMENSIONS	mm	inches	CONT'D	mm	inches
Width	2670	105	Inside turning radius	5329	210
Height	2504	99	Outside turning radius	9144	360
Ground clearance	362	14			
Length	10070	396			
WEIGHT	kg	lbs			
Total	30700	67682			

Dimensions and weights given are for HM800-30 empty machine with 13.63 m³ (17.8 yd³) dump body, 18.00 - 25 tires, standard canopy, standard options, and standard dump body. Net machine weight changes will directly effect the payload. Material density will determine dump body volume figures.

All weights, dimensions, and other data reflect a standard unit unless otherwise stated. RDH reserves the right to change specifications and equipment without notice. Consult RDH Mining Equipment sales representative for specific information.