

# ***MUCKMASTER 350-400***

High production, 3.5 to 4 cubic yard capacity LHD



Bucket capacities between 2.7 m<sup>3</sup> to 3.1 m<sup>3</sup>

Powerful 170 kW (228 hp) engine

Tramming height 2.3 m

Easy access service points

**RDH**  
MINING  EQUIPMENT

*simplifying heavy equipment*

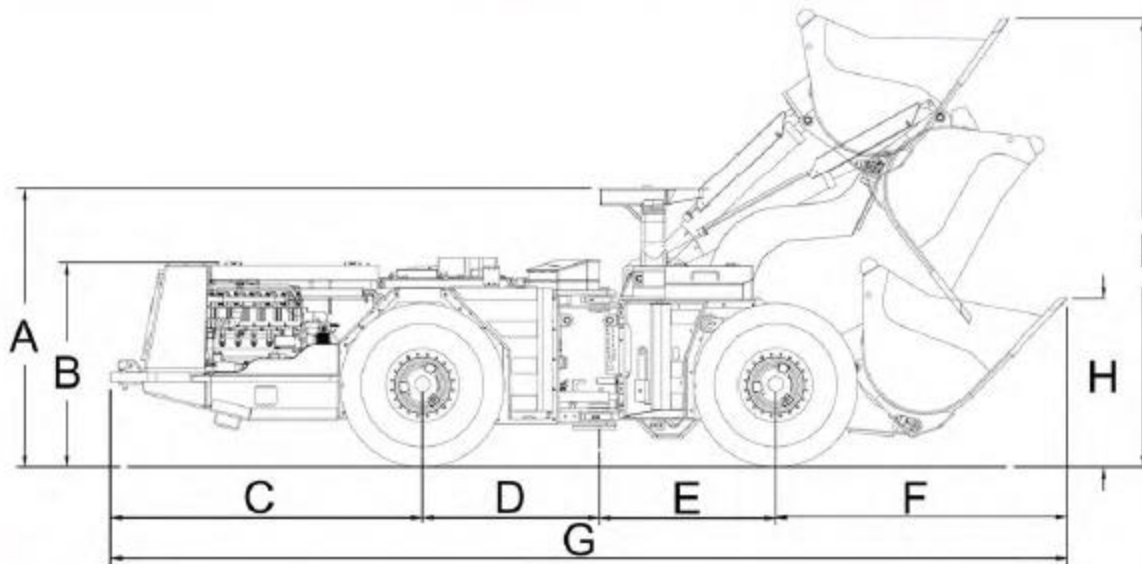

## Dimensions

BUCKET CAPACITY (HEAPED SAE 2:1)	350		400	
	2.7 m <sup>3</sup> mm	3.5 yds <sup>3</sup> in	3.1 m <sup>3</sup> mm	4 yds <sup>3</sup> in
A Height at canopy	2310	91	2310	91
B Height at engine end	1694	67	1694	67
C Rear bumper to centerline of rear axle	2604	103	2604	103
D Centerline of rear axle to centerline of midship	1467	58	1467	58
E Centerline of midship to centerline of front axle	1463	58	1463	58
F Centerline of front axle to tip of bucket	2460	97	2520	99
G Overall length	7994	315	8055	317
H Height to top of bucket lip—trammed	1556	61	1567	62
I Height to top of bucket lip—boom extended	3837	151	3923	154
J Overall width	1918	75	2032	80
K Outside clearance—turning radius	5530	218	5619	221
L Inside clearance—turning radius	3149	124	3149	124
M Articulation angle	40°		40°	
N Width—bucket	1918	75	2032	80
Tire size	14.00 x 24		14.00 x 24	
Approximate weight of standard equipped unit with canopy (empty bucket)	16738 kg / 36900 lbs		17645 kg / 38900 lbs	

All weights, dimensions, and other data reflect a standard configuration unless noted. ©2017 Ingersoll Rand. All rights reserved. For more information, visit us online at [www.ingersollrand.com](http://www.ingersollrand.com).

*simplifying heavy equipment*

## HYDRAULIC SYSTEM

- Variable displacement load sensing, closed center system with a piston pump
- Hydraulic pilot operated joystick steering control.
- Oil level gauge on oil tank, oil filter indicator

## OPTIONAL EQUIPMENT

- Various engine models
- Ejector bucket
- Automatic centralized lubrication system
- Ride control system
- Electric oil filling pump
- ROPS/FOPS approved protective canopy
- ROPS/FOPS approved enclosed cabin
- ANSUL Checkfire fire suppression system
- Fast fill system
- Remote control system
- Reverse camera system
- Fire extinguisher
- Cable reel
- Strobe light
- Quick attach forklift package
- Cold weather package
- Driver door interlock
- Other custom options upon request

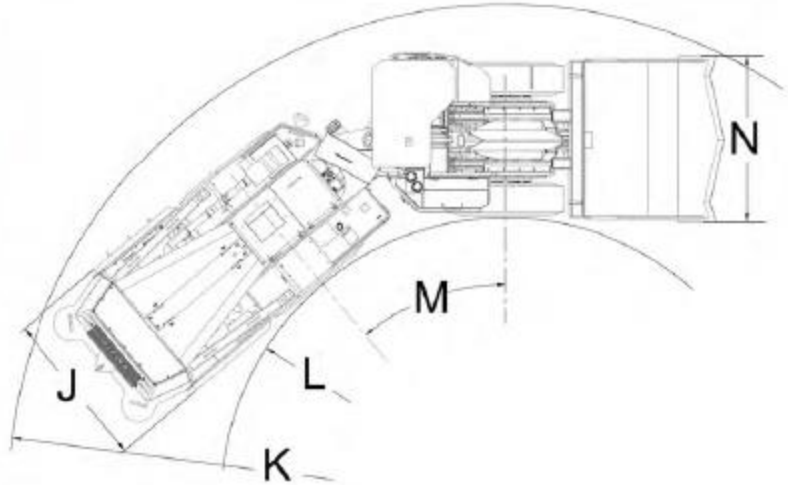

## Carrier

### Powertrain

Engine: CAT C6.6

Power rating at 2200 rpm.....	170 kW / 228 hp
Torque at 1200-1600 rpm.....	809 Nm / 597 lb-ft
Exhaust.....	catalytic purifier with silencer
Air intake .....	Donaldson two-stage
Four wheel drive	
Transmission.....	Dana 32000 series, 4 speed forward / reverse
Converter.....	Dana C270
Axles.....	Dana 37R
Service/emergency/parking brakes.....	spring applied hydraulically released
Remote brake release kit for towing	

### Electrical

Electrical system .....	24 V
Batteries .....	2 x 12 VDC
Tramming/working lights.....	4 front, 2 rear, LED 27 W
Horn and reverse alarm	

### Other Standard Equipment

Central grease point—manual  
 Standard gauges and instrumentation  
 Ansul fire suppression system — manual, 20 lbs, six nozzle  
 Copy Parts/Operators/Service Manuals

All weights, dimensions, and other data apply to standard and stock configurations. CAT reserves the right to change this specification without notice.

*simplifying heavy equipment*

**OUR COMMITMENT  
TO CUSTOMER SATISFACTION,  
QUALITY, AND SERVICE**

At RDH Mining Equipment we are committed to finding innovative and cost-effective ways of increasing equipment productivity while decreasing equipment costs for our customers.

We incorporate the latest technology to ensure the highest standards are met during every step of the manufacturing process.

We stand behind each of our products and continually enhance our product line with exciting innovations that make our equipment invaluable at customer sites around the world.

Our skilled technical staff ensure our drill rigs are engineered to provide the greatest drilling performance to meet the demands of your tight production schedules.

RDH Mining Equipment aims to enhance customer satisfaction through the continual improvement of our processes and is a ISO 9001 registered organization, consistently providing products that meets our customer and applicable statutory and regulatory requirements.



*simplifying heavy equipment*



904 Hwy 64 Alban, Ontario  
Canada POM 1A0

1.800.401.3588 toll  
705.857.2154 ph  
705.857.3265 fax

sales@rdhminingequipment.com  
www.rdhminingequipment.com

