

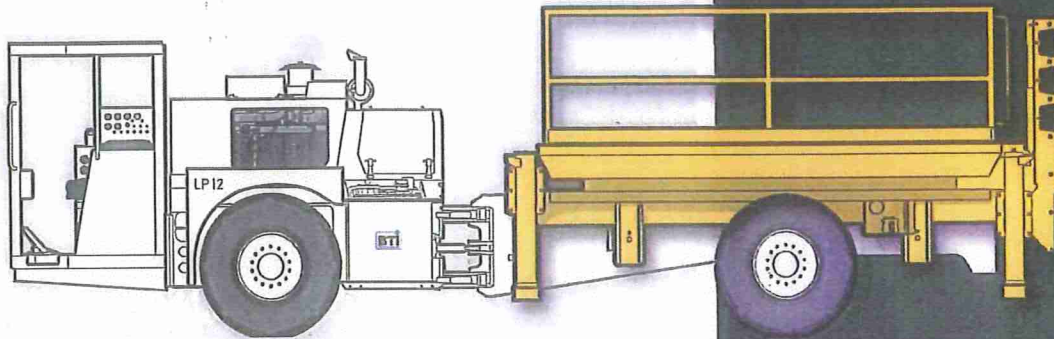

Gladiator Equipment Inc.

SL SERIES - LP12 - MPV Scissorlift Cassette



AT A GLANCE

Weights & Dimensions:

Operating Weight 35,660 lbs (11,664 kg)	Overall Trimming Length 27'-4" (8.32 m)	Outside Turning Radius 20'-11" (6.38 m)	Overall Width 7'-2" (2.18 m)
Trimming Height 8'-4" (2.54 m)	Carrier Articulation +/- 45°	Inside Turning Radius 12'-1" (3.68 m)	
Cassette Weight 8,200 lb (3,727 kg)	Cassette Length 13'-2" (4.01 m)	Cassette Width 7'-0" (2.13 m)	

Note: weights & dimensions are nominal and vary depending on final engine, operator's enclosure & option configuration.

Engine Configurations:

● Deutz BF4M1013C 122 hp (91 kW) @ 2300 rpm MSHA/Tier II	▲ Caterpillar C4.4 ACERT 127 hp (95 kW) @ 2200 rpm Tier III
--	---

● Standard ▲ Optional

FEATURES & BENEFITS

Cassette System offers single vehicle solution for multiple task requirements

Simple four pin connection provides fast loading/unloading of cassette with safe operation.

Large deck with handrails and kick plate for safety. High lift provides workers safe access to suspended services throughout the mine.

See MPV Base Carrier for carrier specifications

Scissor Deck
7'-0" x 12'-0" (2.13 m x 3.66 m)

Load Capacity
5,000 lb (2,273 kg)
at 12'-0" (3.66 m) Lift Floor Height

Dual Safety Lock Hydraulic Cylinders
42" (1067 mm) Handrails

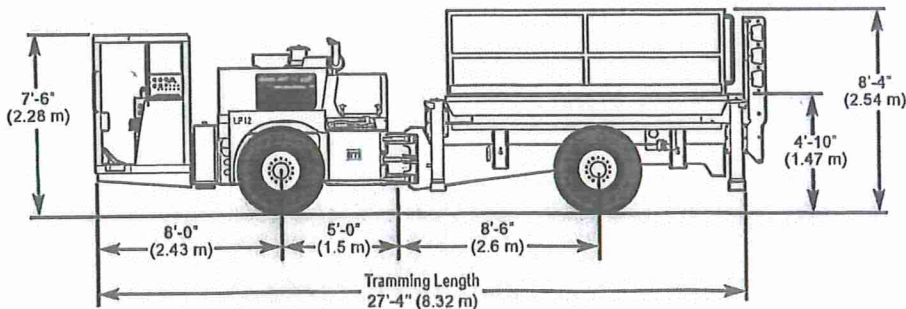
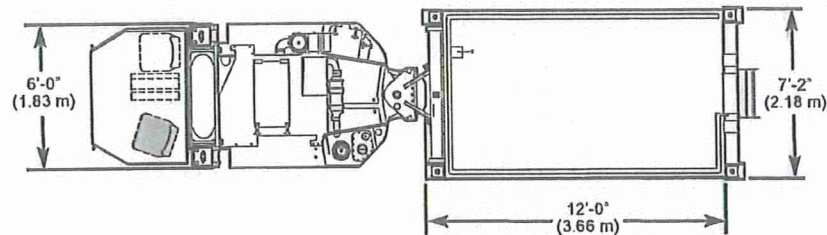

OPTIONS

- Protective operator structure
- Seating configurations
- Air intake system
- Exhaust system
- Hydraulic filling system
- Tires
- Fire suppression system
- Wheel chocks
- Deck lighting
- Air and water manifold
- Telescopic work lights
- Drill steel rack

SL SERIES (LP12) SCISSOR LIFT CARRIER COMPONENTS

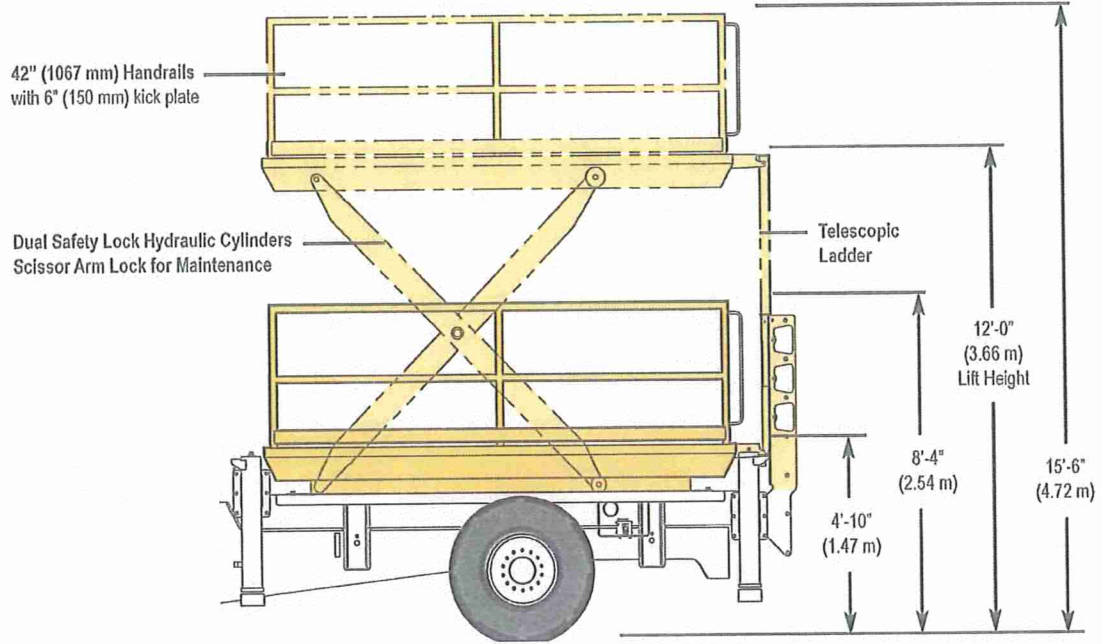
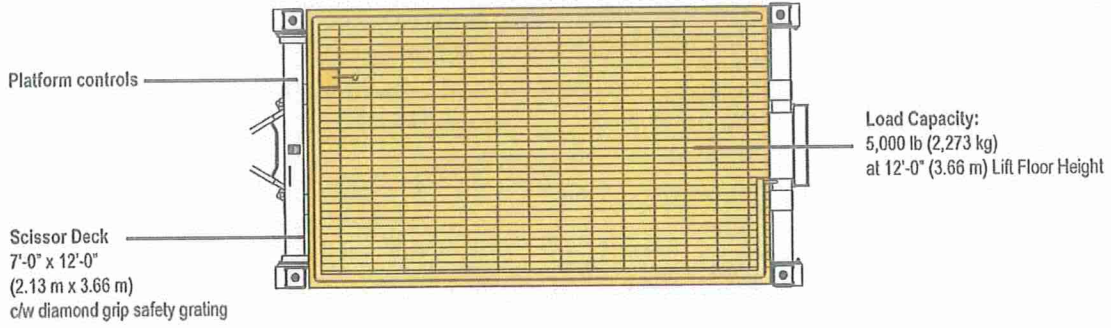

DRIVING SPECIFICATIONS

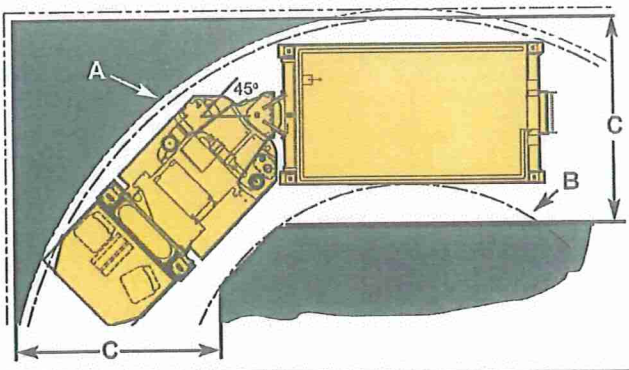

Turning Radius

Turning radius: +/- 45° articulation

		Fully Enclosed Cab	ROPS/FOPS Cab
A	Outside Turning Radius	21'-5" (6.52 m)	20'-10" (6.36 m)
B	Inside Turning Radius	12'-1" (3.7 m)	
C	Minimum Mine Tunnel Width	11'-6" (3.5 m)	11'-0" (3.34 m)

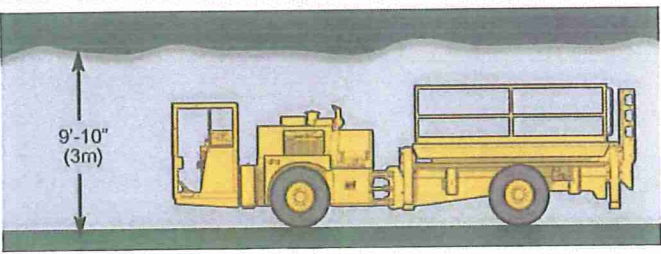

Recommended Drift Height

BTI recommends a minimum drift height with cab: 9'-10" (3 m)