

Scooptram ST710

Technical specification

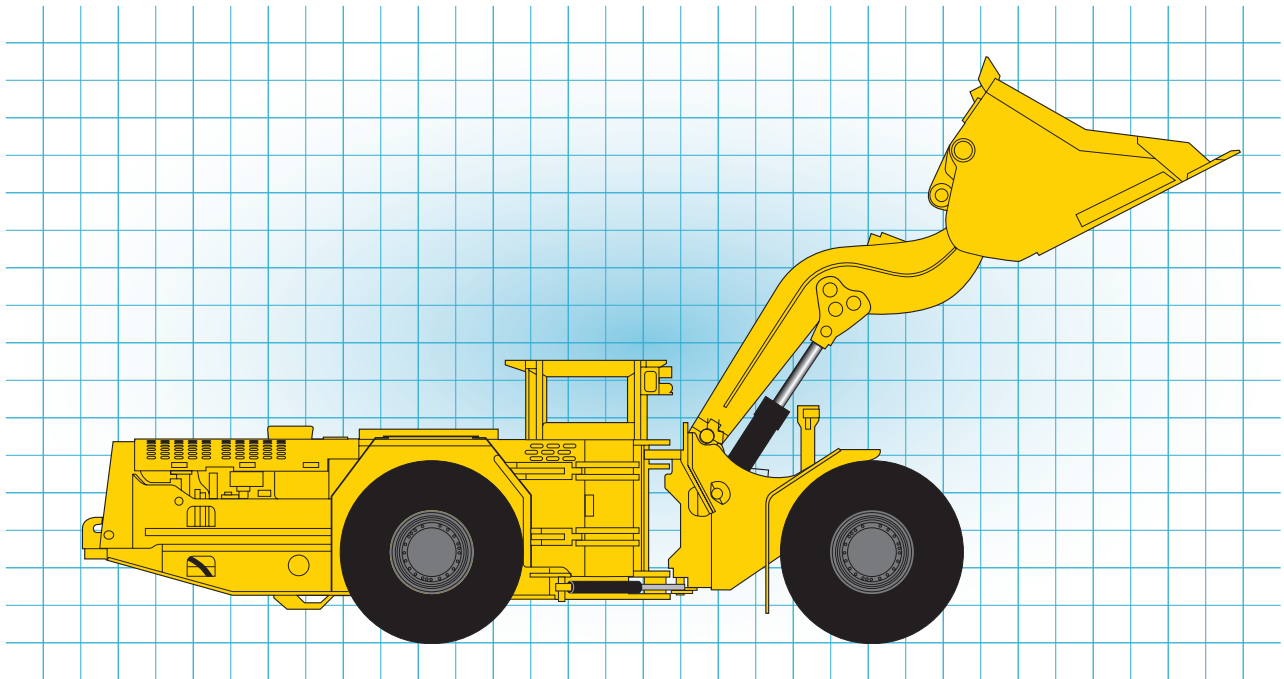

The Scooptram ST710 is a compact 6.5 metric ton underground loader with an ergonomically designed operator's compartment especially for narrow-vein mining.

Features

Load frame

- A Z-bar front-end for efficient loading and mucking.
- An aggressively designed "high shape" factor bucket, reducing the need for multiple passes to fill the bucket.
- Easy to change bucket and cylinders with split-cap pin retention system.
- Boom support and lock for safe work under boom.

Operator's compartment

Ergonomically and spacious designed compartment for maximum safety and minimal operator fatigue with:

- Maximized legroom because of the Atlas Copco's Footbox.
- Comfortable operator's seat offering improved ergonomic positioning, body orientation and generous shoulder and hip room.
- Compliant with sound and vibration regulations to minimize operator's fatigue; reduced noise level to 82 dB(A) inside the cab.

Power frame

- Atlas Copco unique powertrain including an up-box, and a combined transmission and converter allowing space for the Footbox plus a low and short rear end.
- Electronic transmission and engine control systems for smooth and precise shifting.
- A high power-to-weight ratio complemented by a fully integrated powertrain, automatically matching the gear selection to the load - producing a high tractive effort without wheel spin.
- Stacked V-core radiator and charge air cooler; easy to replace damaged tubes and to clean.

General

- Great serviceability with centralized service points.
- Long-life roller bearing centre hinge.
- Anti skid material at service access points.

Specifications

Capacities	
SAE regulations	
Tramming capacity	6 500 kg
Breakout force, hydraulic	14 200 kg
Breakout force, mechanical	10 347 kg

Motion times	
Boom	
Raising	6.1 seconds
Lowering	4.6 seconds
Bucket	
Dumping	1.3 seconds
Rolling back	1.7 seconds

Matching vehicles
For Scooptram ST710
Minetruck MT2010

Engine

- Deutz DieselBF6M1013FC-MVS, Tier/Stage 1
- Power Rating at 2300 rpm 149 kW/200 hp
- Maximum torque at 1400 rpm 805 Nm
- MSHA part 32 ventilation rate 481 m³/min
- Ventilation particulate index 113 m³/min
- Rock Tough purifier and silencer.
- Dry type air cleaner.
- Exhaust heat protection.
- Remote engine oil drain.
- Cooling package with V-core radiator.

Upbox

Power transmitted through a 1:1 gear ratio box.
Superior.....AC826V

Transmission and converter

- Automatic power shift with integral converter, fully modulated 4 speed shifting, forward/reverse.
- FunkDF150

Axles

- Spiral bevel differential, full floating, planetary wheel end drive.
- Rock Tough.....406
- Rear axle, trunnion mounted.
- Degree of oscillation14° (7° on each side)
- Differentials:
 - Front.....No spin
 - Rear.....Standard

Brakes

- Fully enclosed, force cooled, multiple wet discs at each wheel end.
- Service/parking/emergency brakes SAHR

Electrical system

- System voltage..... Start & accessories 24 V
- Alternator, high output.
- Hydraulic warning system.
- Rock Tough protection lights.
- Isolation switch lockout.

Tyres

Tubeless, smooth, extra deep tread design for underground mine service on demountable rims.

- Tyre size, front and rear.....17.5x25, 20 ply STMS L-5S

** As applications and conditions vary, Atlas Copco recommends that the user consults with tyre suppliers to obtain the optimum tyre selection.*

Operator's compartment

- Canopy; MSHA-ISO ROPS/FOPS approved.
- Side seated operator for bi-directional operation.
- Grammer seat with retractable seat belts.
- Open door retainer.
- Two pilot operated joysticks for steering, dump & hoist control.
- Push button transmission control on dump and hoist lever.
- Foot-box.

Hydraulic system

- Bucket float.
- System pressure, dump and hoist 20.7 MPa
- System pressure, steering 22.4 MPa
- Hydraulic tank capacity 87 liters
- Filtration, return line..... 4.0 µm
- Heavy duty gear type pumps.
- Door steering interlock.
- Cylinders, double acting, chrome plated stems, diameter:
 - Steer cylinders (2)80 mm
 - Hoist cylinders (2).....160 mm
 - Stabilizer cylinder 180 mm

Fuel

- Fuel tank capacity 191 litres
- Fuel consumption, full load 41 litres/hour
- Fuel filtration 3.0 µm
- Anti-siphon fuel supply.

Turning radius

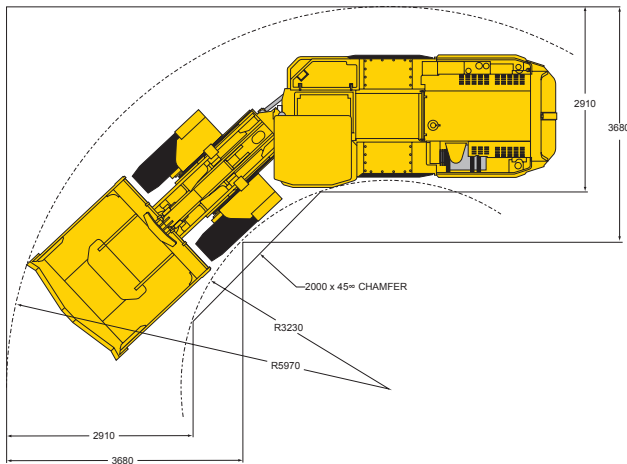

Recommended drift size

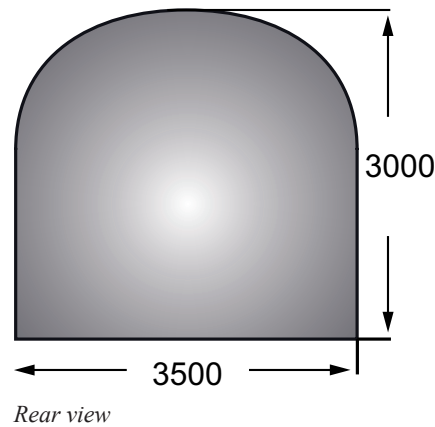

- Turning angle $\pm 42.5^\circ$.
- Dimensions shown are based on standard vehicle configuration with 27 mm tyre deflection.
- All dimensions are shown in millimetres.

Grade performance

Standard configuration, bucket empty

Percent grade	0.0	2.0	4.0	6.0	8.0	10.0	12.5	14.3	16.0	18.0	20.0	25.0	30.0
Ratio					1:12	1:10	1:8	1:7			1:5	1:4	
1st gear (kph)	4.8	4.7	4.7	4.6	4.5	4.5	4.4	4.4	4.3	4.3	4.2	4.1	4.0
2nd gear (kph)	7.9	7.8	7.6	7.5	7.3	7.2	7.0	6.8	6.7	6.5	6.3	5.8	5.1
3rd gear (kph)	15.3	14.7	14.1	13.5	12.7	12.0	11.0	9.7	8.4	6.7	4.7		
4th gear (kph)	24.8	23.1	21.3	18.8	14.1	9.9							

Standard configuration, bucket loaded

Percent grade	0.0	2.0	4.0	6.0	8.0	10.0	12.5	14.3	16.0	18.0	20.0	25.0	30.0
Ratio					1:12	1:10	1:8	1:7			1:5	1:4	
1st gear (kph)	4.7	4.7	4.6	4.5	4.4	4.4	4.3	4.2	4.1	4.1	4.0	3.8	3.5
2nd gear (kph)	7.8	7.6	7.4	7.2	7.0	6.8	6.5	6.3	6.0	5.8	5.4	4.1	2.6
3rd gear (kph)	15.0	14.2	13.4	13.3	11.0	9.3	6.6	3.9					
4th gear (kph)	23.9	21.3	17.7	11.7									

Optional equipment

Main frame

- Optional bucket sizes.
- EOD buckets.
- Boom up lock device.
- Wheel chocks and chock brackets.

Ergonomic

- Enclosed cab.
- Air Conditioner (cab).
- Heater (cab and canopy).

Hydraulic System

- Brake release tow hook.

System

- Ansul checkfire, autofire suppression.

- Ansul single bottle fire suppression with Engine kill.
- Electric fill pump for hydraulic oil.
- Lincoln auto lube with timer.
- Wiggins fast fuel fill.
- Second fire extinguisher.

Electrical system

- Audio-visual reverse alarm.
- Batteries, dry.
- Loadrite weighing system.
- 12/24 voltage converter.

Controls and instruments

- Blockout 3rd and 4th gears.
- Blockout 4th gear.

- Extended data gauge package.
- Deutz diagnostic data reader.
- DDEC Series 40 diagnostic tools.
- Ride control.
- Scooptram RRC (line of sight Radio Remote Control)
- Scooptram RRC interface only.

Power unit

- Detroit Diesel Series 40 Engine, 157kW/210HP.
- Cold weather packages for 120V or 240V, may include:
 - Block heater.
 - Ether start.
 - Battery warmer.

- Fuel heater.
- Arctic oil.
- Epoxy coated radiator.

Documentation

- Extra DDEC Engine manual kit.
- LinkOne parts book, CD.
- LinkOne viewer.
- Parts manual - plasticised
- Service manual - plasticised

Other

- Face mechanics tool set.
- Shop mechanics tools set.
- Special tools set.
- Parts kit - 1 000 hour consumables.
- EC specification.

Buckets

Bucket data		STD				
Material density (t/m ³)		1.8	2.0	2.2	2.4	2.6
Volume, nominal heaped (m ³)		3.4	3.2	3.0	2.8	2.6
Width, bucket (mm)	W	2 040	2 040	2 040	2 040	2 040
Tramming position: Axle centerline to bucket lip (mm)	T1	3 000	2 920	2 895	2 830	2 750
Tramming position: Ground to bucket tip (mm)	T2	1 340	1 295	1 280	1 220	1 135
Truck loading: Reach (mm)	L1	1 590	1 520	1 500	1 440	1 360
Raised position: Back height, max. (mm)	H1	4 375	4 375	4 375	4 375	4 375
Raised position: Bucket tip, height (mm)	H2	1 635	1 695	1 705	1 750	1 825

Dimensions and weights

- Approximate weight18 200 kg
- Axle load, front end8 372 kg
- Axle load, back end9 828 kg

Standard equipped vehicle with empty bucket.

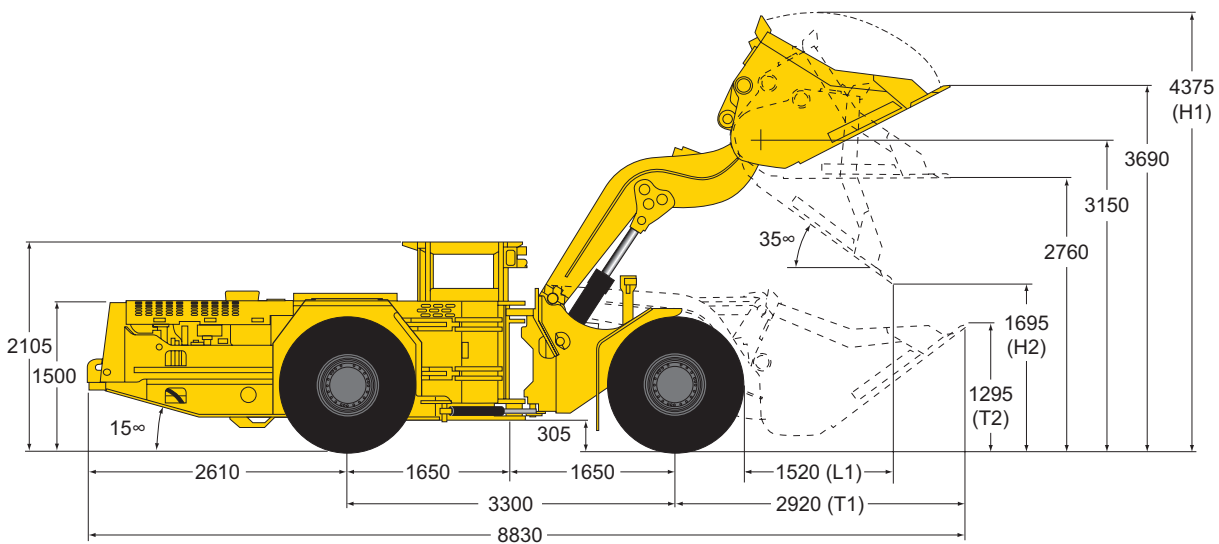

Side view

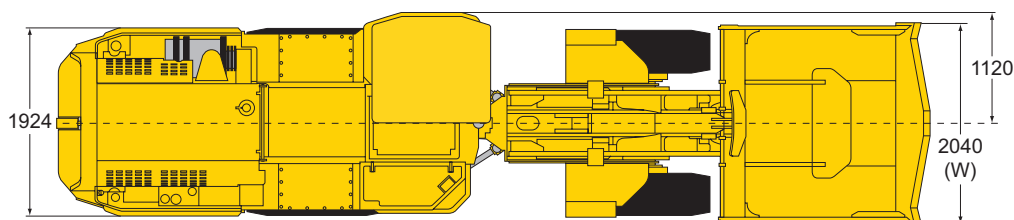

Top view

- Dimensions shown are based on standard vehicle configuration with 27 mm tyre deflection.
- All dimensions are shown in millimetres.