

The ST-1020 introduction



Scooptram ST1020

- 10 metric ton tramming capacity
- New, ergonomic operator's compartment
- Unique power train
- Matching Mine truck MT431B/436B



The ST1020 is a rugged built Scooptram for unparalleled productivity in any underground mine.



We have developed an operator's cab that provides a safe environment and the most comfortable place to work.

Cabin

MSHA ISO Approved

- Roll Over Protection Structure (ROPS)
- Falling Object protective structure(FOPS)

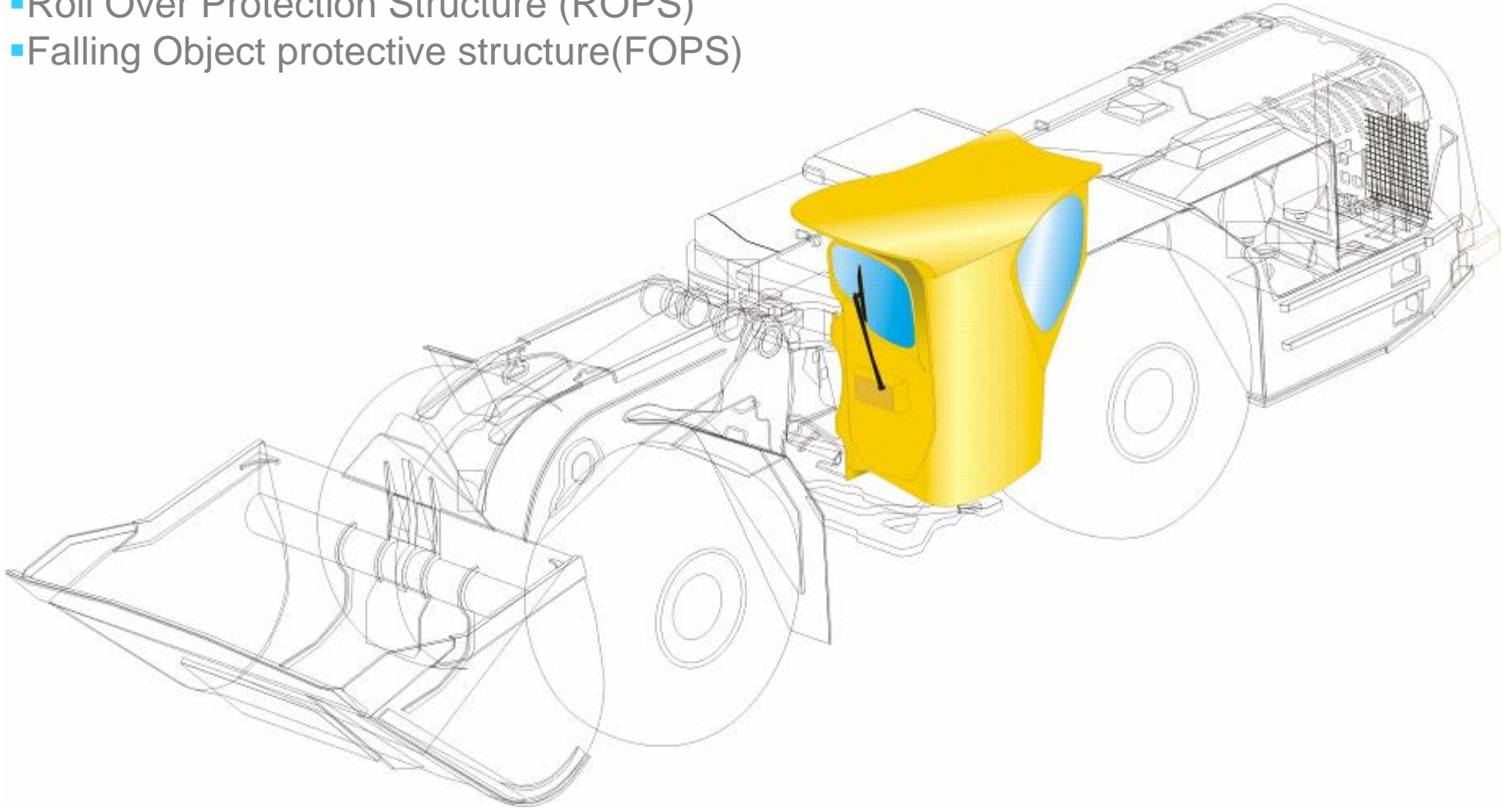

Brake system

Dana "Posi-stop" brake

- SAHR "Spring Applied Hydraulic Released"
- Simplest/Compact
- Patented Technology
- 15,000 Hour Brake Life
- Minimizes Risk of Abuse
- Wheel End Brake

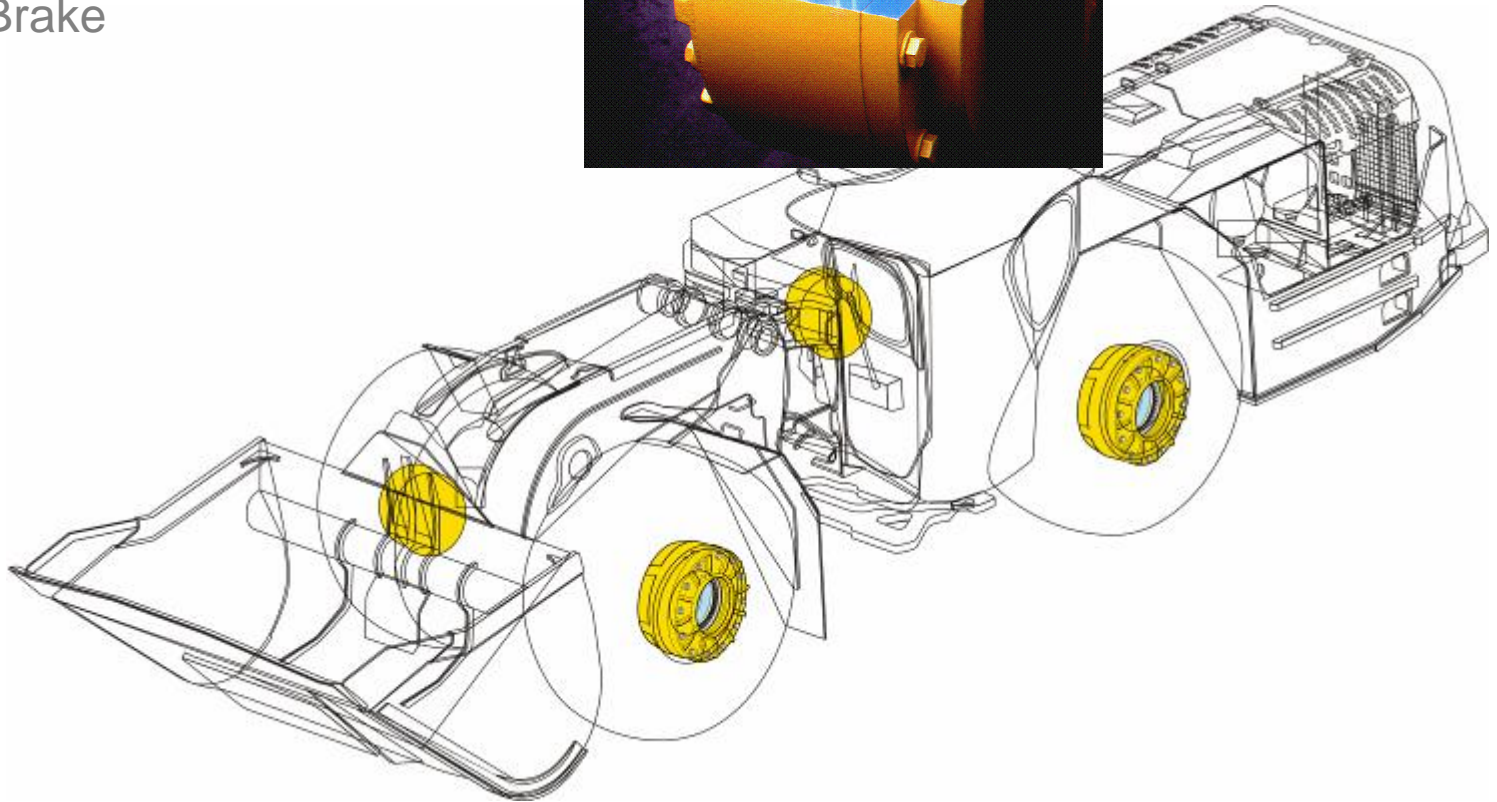
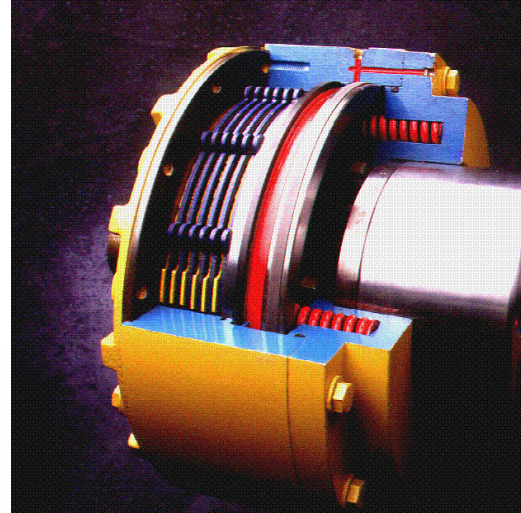

Operators panels

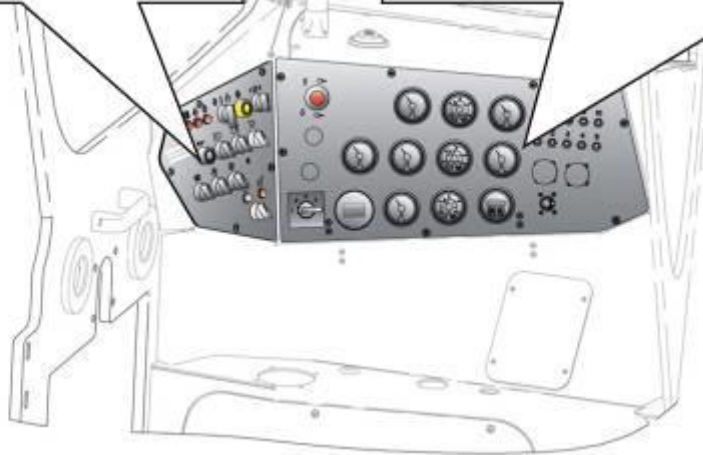
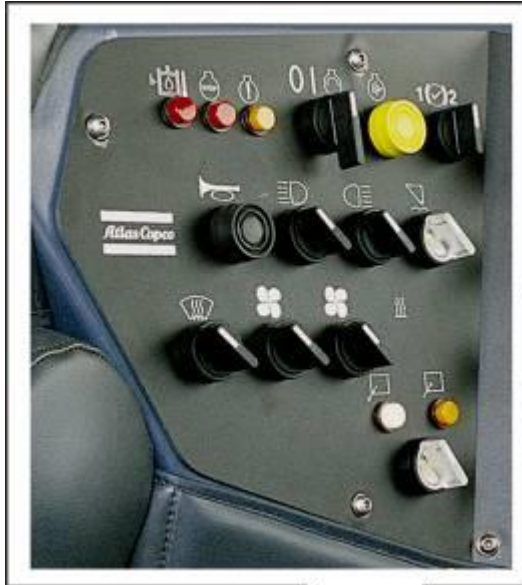

Dimensions

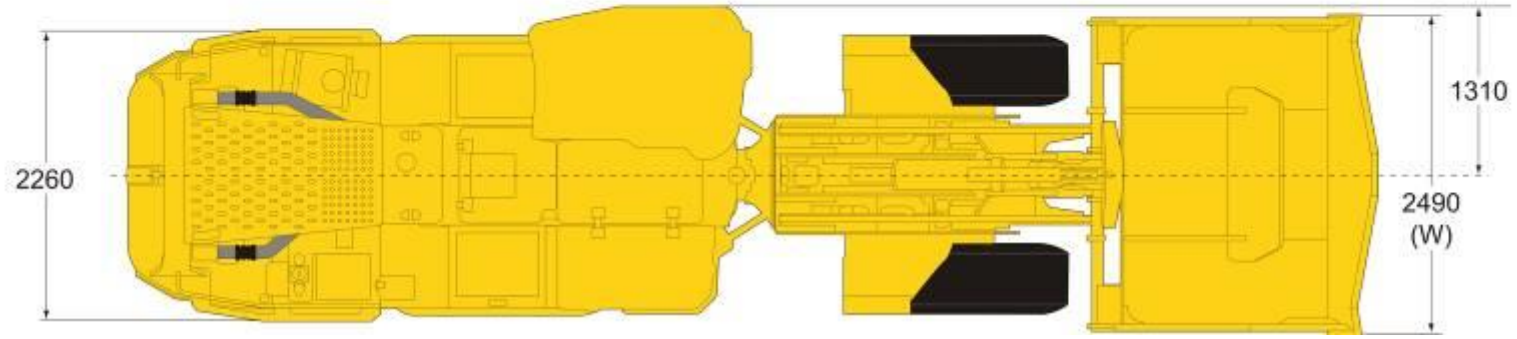
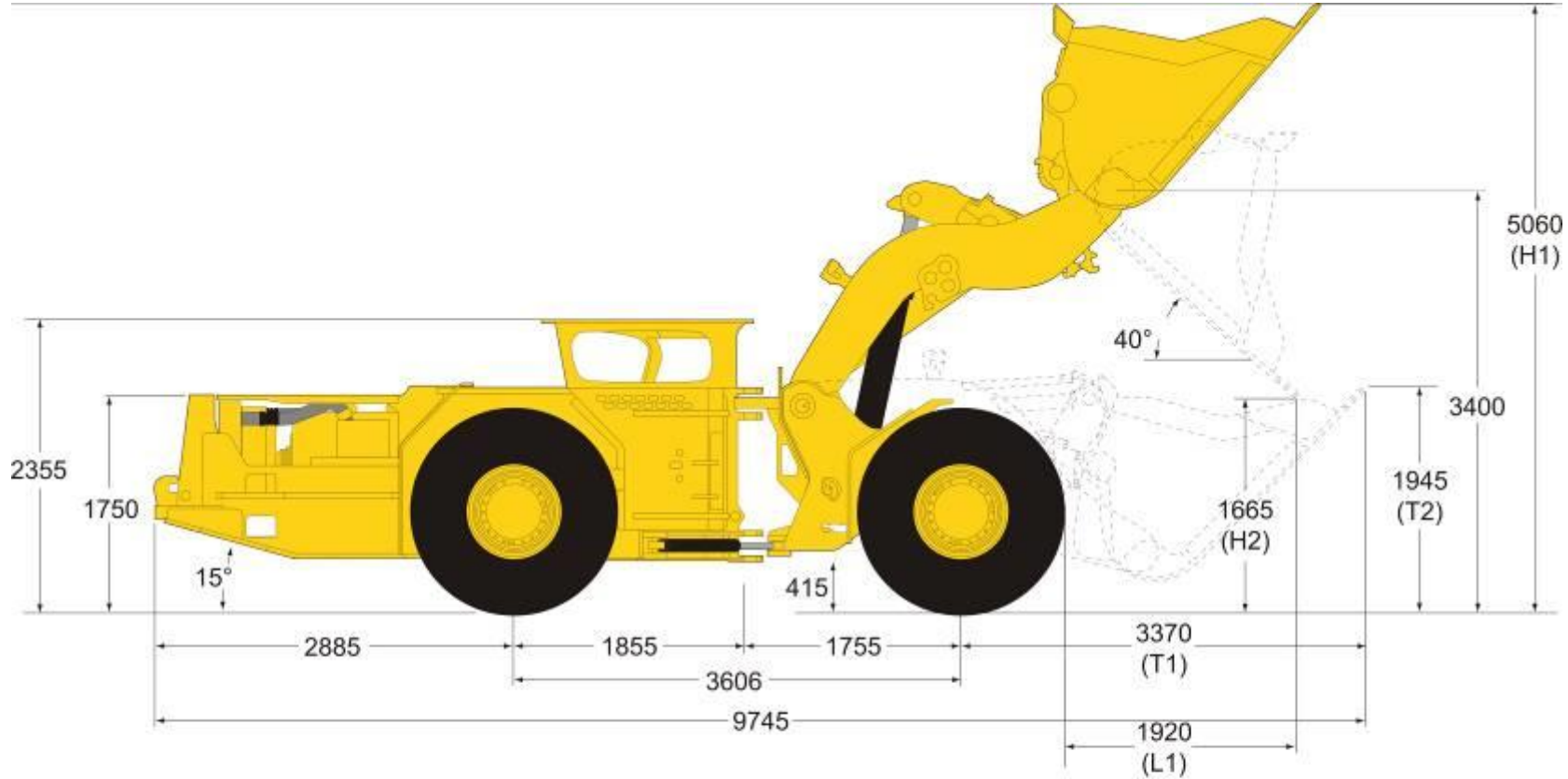

Dimensions

